

TAWIGRIP GLASS LIFTER

This TAWIGrip has an electric vacuum source and four suction cups, Ø190 mm, on two cross bars. Max capacity 375 lbs.

The window is picked up from a vertical position, tilted to horizontal position where assembly work takes place. The window is then tilted to 70° and positioned in a wall module.

Both vacuum source and tilt unit is electric on this TAWIGrip, no compressed air necessary.

An electric motor creates the correct level of vacuum in the yoke system and then shuts down. If the underpressure sinks below 60%, the pump automatically restarts to reach correct level.



- TAWIGrip vacuum gripper can lift, tilt and rotate sheet metal, glass and laminated panels.
- Choose between: TAWIGrip with Pneumatic Vacuum Source or Electric Vacuum Source.
- Horizontal: Up to 1100 lbs or more on request. Vertical: Up to 550 lbs.
- Choose between: Horizontal-Horizontal, Horizontal-Vertical, Vertical-Vertical
- Safe, two-handed release function
- Visual control of the vacuum level
- Easy-to-use control board
- Twin chamber vacuum system
- Light weight design



TAWI

Lyftman over head crane systems and jib cranes

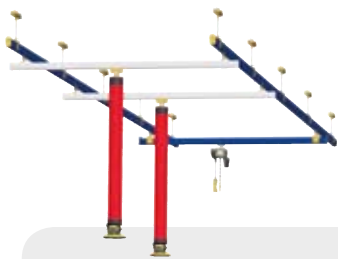

For production lines with several working stations.
A separate crane bridge is installed for each station. There is no limit to the length of this gantry, 50-60 metres is common.



Basic overhead x-y crane system.
Competitive pricing, fast deliveries, high quality and easy installation is the secret behind this popular solution.

Lyftman single bridge crane systems max 3300 lbs

Profile type	(mm)	88 lbs	130 lbs	175 lbs	275 lbs	550 lbs	1100 lbs	2200 lbs	3300 lbs
LR86	N max	3750	3200	2900					
	M	80	80	80					
	K	L/1,5*70+G	L/1,5*70+G	L/1,5*70+G					
	A max	4000	3400	3000					
	R	150-778	150-778	150-778					
	J	150	150	150					
	G	80	80	80					
LR113	N max	6000	5200	4700	3900				
	M	110	110	110	110				
	K	L/1,5*70+G	L/1,5*70+G	L/1,5*70+G	L/1,5*70+G				
	A max	6000	6000	5300	4400				
	R	200-828	200-828	200-828	200-828				
	J	190	190	190	190				
	G	110	110	110	110				
LR120	N max	8000	8000	7000	6100	4700	2300		
	M	105	105	105	105	105	220		
	K	L/1,5*70+G	L/1,5*70+G	L/1,5*70+G	L/1,5*70+G	L/1,5*70+G	L/1,5*70+G		
	A max	8000	8000	8000	7100	5300	3700		
	R	285-883	285-883	285-883	285-883	285-883	285-883		
	J	250	250	250	250	250	250		
	G	105	105	105	105	105	220		
LR170	N max	-	-	8000	8000	8000	6300	3300	2300
	M	-	-	110	110	110	110	230	230
	K	-	-	L/1,5*70+G	L/1,5*70+G	L/1,5*70+G	L/1,5*70+G	L/1,5*70+G	L/1,5*70+G
	A max	-	-	8000	8000	8000	7100	3900	2700
	R	-	-	285-883	285-883	285-883	285-883	285-883	285-883
	J	-	-	250	250	250	250	250	250
	G	-	-	110	110	110	110	230	230

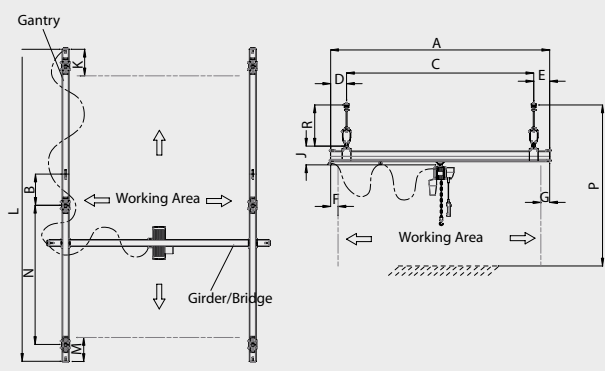

LRP/LRV jib arms up to 1100 lbs

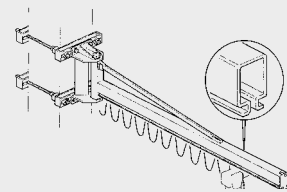
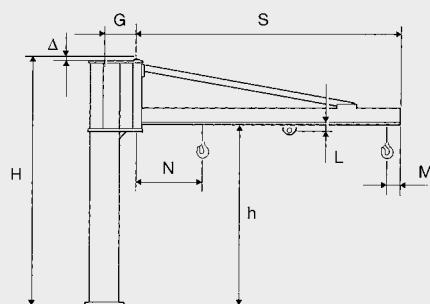

Chain hoist must be ordered separately, not included in jib crane delivery.
Fixing system for floor/wall NOT INCLUDED.

Lifting capacity (kg)	Arm S		Size of jib crane	LRV Wallmounted Jib Cranes Channel Profile							Weight crane (kg)	LRP Column Jib Crane, Channel profile											
	Nominal length (m)	True length (mm)		Art. nr.	Dimension (mm)							Total height H (m)	Art. Nr	Under-beam h (mm)	Dimensions (mm)				Weight (kg)				
					A	B	C	D	E	F					Ø	G	L	M	N	Δ	Crane	Column/m	
63	4	4056	A	LRV4/63	170	552	664	200	594	150	15	74	3	LRP4/63	2496	220	34	125	585	12	174	18	
	5	5056	A	LRV5/63	170	552	664	200	594	150	15	87	3	LRP5/63	2496	220	34	125	645	12	137	18	
	6	6056	B	LRV6/63	170	552	664	200	594	150	15	100	3	LRP6/63	2496	255	34	125	730	12	182	28	
	7	7056	B	LRV7/63	170	552	664	200	594	150	15	113	3	LRP7/63	2496	255	34	125	790	12	195	28	
	125	2	2056	A	LRV2/125	170	552	664	200	594	150	15	48	3	LRP2/125	2496	220	34	125	525	12	98	18
		3	3056	A	LRV3/125	170	552	664	200	594	150	15	61	3	LRP3/125	2496	220	34	125	585	12	111	18
		4	4066	B	LRV4/125	170	552	664	200	594	150	15	74	3	LRP4/125	2496	255	34	125	610	12	156	28
5		5066	B	LRV5/125	170	552	664	200	594	150	15	87	3	LRP5/125	2496	255	34	125	670	12	169	28	
6		6066	C	LRV6/125	210	820	930	250	870	190	22	135	3,5	LRP6/125	2738	310	34	125	800	17	253	34	
7		7066	C	LRV7/125	210	820	930	250	870	190	22	150	3,5	LRP7/125	2738	310	34	125	860	17	268	34	
250		2	2066	B	LRV2/250	170	552	664	200	594	150	15	48	3	LRP2/250	2496	255	34	125	550	12	130	28
	3	3066	B	LRV3/250	170	552	664	200	594	150	15	61	3	LRP3/250	2496	255	34	125	610	12	143	28	
	4	4066	C	LRV4/250	210	820	930	250	870	190	22	105	3,5	LRP4/250	2738	310	34	125	680	17	223	34	
	5	5066	C	LRV5/250	210	820	930	250	870	190	22	120	3,5	LRP5/250	2738	310	34	125	740	17	238	34	
	6	6066	D	LRV6/250	210	820	930	250	870	190	22	202	3,5	LRP6/250	2738	360	40	140	850	17	381	51	
	7	7066	D	LRV7/250	210	820	930	250	870	190	22	228	3,5	LRP7/250	2738	360	40	140	910	17	407	51	
	500	2	2036	C	LRV2/500	210	820	930	250	870	190	22	75	3,5	LRP2/500	2738	310	34	250	745	17	193	34
3		3066	C	LRV3/500	210	820	930	250	870	190	22	90	3,5	LRP3/500	2738	310	34	250	805	17	208	34	
4		4066	D	LRV4/500	210	820	930	250	870	190	22	113	3,5	LRP4/500	2738	360	34	250	850	17	292	51	
5		5066	D	LRV5/500	210	820	930	250	870	190	22	129	3,5	LRP5/500	2738	360	34	250	910	17	308	51	
6		6066	E	LRV6/500	255	1100	1240	300	1160	220	34	270	4	LRP6/500	2980	415	40	140	860	20	576	73	
7		7066	E	LRV7/500	255	1100	1240	300	1160	220	34	300	4	LRP7/500	2980	415	40	140	920	20	606	73	

