

TAWIGrip vacuum grippers for sheet/panel up to 1100 lbs

TAWIGRIP DOOR LIFTER

These doors weigh 175 lbs. Before the investment in a TAWIGrip vacuum gripper, these were all lifted manually.

The door is gripped and picked up from a vertical position and tilted 90 degrees into a horizontal position.

It is rotated 90 degrees in the horizontal plane and then tilted to be placed in a vertical position in the rack.

Even though the working area is small and ceiling height low, it is possible to install this lifting aid. The TAWIGrip is suspended in a Lyftman underbraced jib crane UPM, arm in steel profile, max 330 lbs, max arm length 4 m.



- TAWIGrip vacuum gripper can lift, tilt and rotate sheet metal, glass and laminated panels.
- Choose between: TAWIGrip with Pneumatic Vacuum Source or Electric Vacuum Source.
- Horizontal: Up to 1100 lbs or more on request. Vertical: Up to 550 lbs.
- Choose between: Horizontal-Horizontal, Horizontal-Vertical, Vertical-Vertical
- Safe, two-handed release function
- Visual control of the vacuum level
- Easy-to-use control board
- Twin chamber vacuum system
- Light weight design



TAWI

Lyftman over head crane systems and jib cranes

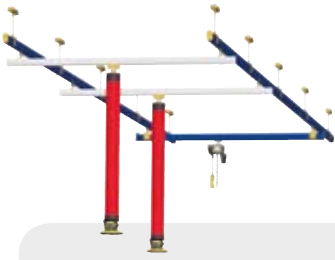

For productions lines with several working stations. A separate crane bridge is installed for each station. There is no limit to the length of this gantry, 50-60 metres is common.



Basic overhead x-y crane system. Competitive pricing, fast deliveries, high quality and easy installation is the secret behind this popular solution.

Lyftman single bridge crane systems max 3300 lbs

Profile type	(mm)	88 lbs	130 lbs	175 lbs	275 lbs	550 lbs	1100 lbs	2200 lbs	3300 lbs
LR86	N max	3750	3200	2900					
	M	80	80	80					
	K	L/1,5*70+G	L/1,5*70+G	L/1,5*70+G					
	A max	4000	3400	3000					
	R	150-778	150-778	150-778					
	J	150	150	150					
	G	80	80	80					
LR113	N max	6000	5200	4700	3900				
	M	110	110	110	110				
	K	L/1,5*70+G	L/1,5*70+G	L/1,5*70+G	L/1,5*70+G				
	A max	6000	6000	5300	4400				
	R	200-828	200-828	200-828	200-828				
	J	190	190	190	190				
	G	110	110	110	110				
LR120	N max	8000	8000	7000	6100	4700	2300		
	M	105	105	105	105	105	220		
	K	L/1,5*70+G	L/1,5*70+G	L/1,5*70+G	L/1,5*70+G	L/1,5*70+G	L/1,5*70+G		
	A max	8000	8000	8000	7100	5300	3700		
	R	285-883	285-883	285-883	285-883	285-883	285-883		
	J	250	250	250	250	250	250		
	G	105	105	105	105	105	220		
LR170	N max	-	-	8000	8000	8000	6300	3300	2300
	M	-	-	110	110	110	110	230	230
	K	-	-	L/1,5*70+G	L/1,5*70+G	L/1,5*70+G	L/1,5*70+G	L/1,5*70+G	L/1,5*70+G
	A max	-	-	8000	8000	8000	7100	3900	2700
	R	-	-	285-883	285-883	285-883	285-883	285-883	285-883
	J	-	-	250	250	250	250	250	250
	G	-	-	110	110	110	110	230	230

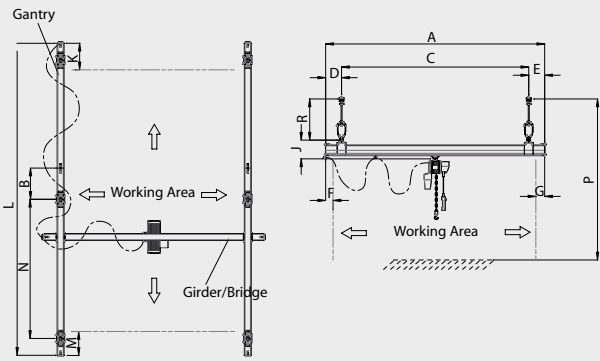

Lyftman UVM jib arm in steel profile LR120 max 80 kg, LR170 max 150 kg



*The jib arm delivery includes arm and bracket, 1 pce trolley for lifting equipment, 3 pcs trolley for cable/air tube with leather strap, end stop, load signs and 4 pcs bolt M16.

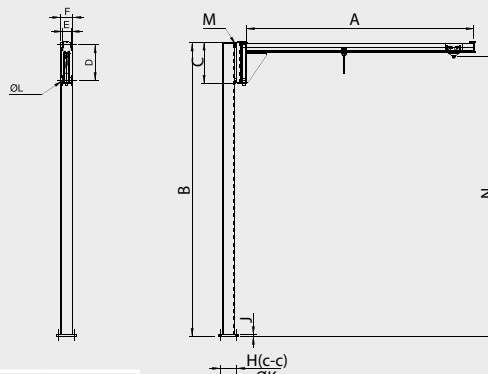

Jib arm* UVM (mm)									
Type	Load (lbs)	A	C	D	E	F	L	N	Arm profile
UVM2/80	175	2000							
UVM3/80	175	3000	521	416	150	200	Ø18	B-185	LR120
UVM4/60	130	4000							
UVM4/150	330	ON REQUEST							LR170
Column for jib arm UVM (mm)									
Type	For jib arm:	B	G	H	J	K	M		
LPM15361U	UVM2/80								
	UVM3/80	CUSTOMIZED	300	250	20	Ø24	M16		
	UVM4/60								
UPM4/150	UVM4/150	ON REQUEST							

